

DSC

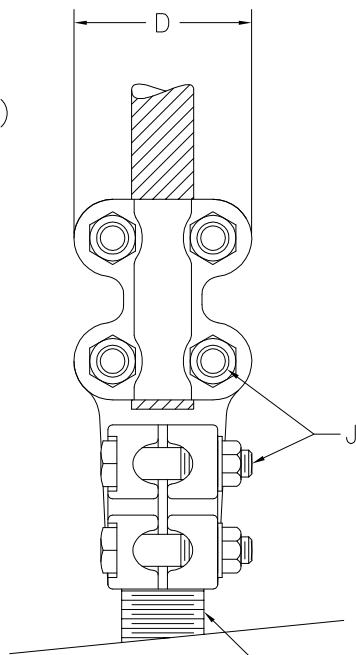

STUD  
(BY CUSTOMER)

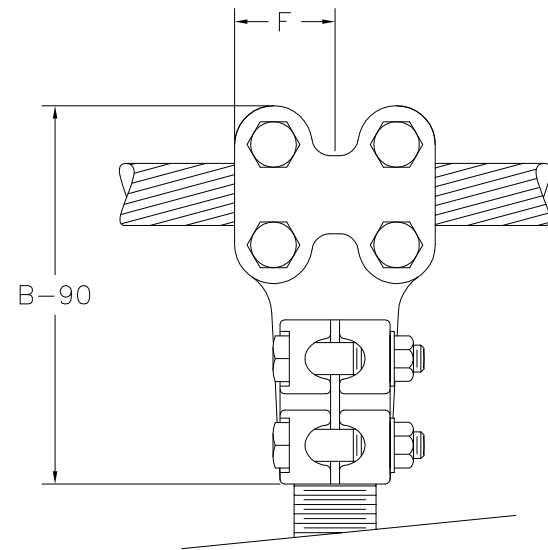

DSC-90

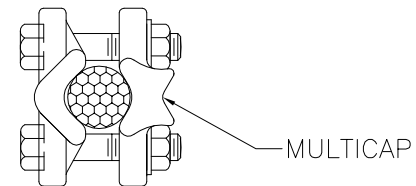

MULTICAP

NOTES:

1. MATERIAL: CASTINGS – ELECTRICAL BRONZE  
HARDWARE – STAINLESS STEEL
2. DIMENSION IN INCHES.
3. ALL CONNECTORS ARE SUPPLIED WITH MULTICAPS
4. TO OBTAIN PART WITH TIN PLATING ADD "TP" SUFFIX TO CATALOG NUMBER. EXAMPLE: (DSC-20100-12-TP)
5. STUD CONNECTORS WITH SMOOTH THREADS HAVE THE SAME DIMENSIONS AS THE THREADED STUD.

59619	2/23/15	JLB	JLB
EC #	DATE	CHG BY	RESP ENG
DESC OF DWG: UPDATE DRAWING TO AUTOCAD FILE ADD PART NUMBER DSC-094050-0-3 TO TABLE -- -- REASON(S) FOR CHANGE: -- DISPOSITION OF MAT'L: --			

ANDERSON<sup>®</sup>

CONFIDENTIAL: THIS DRAWING AND ITS CONTENTS ARE CONFIDENTIAL AND THE EXCLUSIVE PROPERTY OF HUBBELL POWER SYSTEMS. NO PUBLICATION, DISTRIBUTION OR COPIES MAY BE MADE WITHOUT THE WRITTEN CONSENT OF HUBBELL POWER SYSTEMS. HUBBELL POWER SYSTEMS UNPUBLISHED. ALL RIGHTS RESERVED UNDER THE COPYRIGHT LAWS.

		<b>HUBBELL<sup>®</sup> POWER SYSTEMS</b>	
TITLE STUD CONNECTOR STUD TO CABLE			
SIZE C	DWG NO. C-2888	CAT / PART / ASSY NO. SEE TABLE	REV 29
DO NOT SCALE THIS DRAWING		DRN BY RLW	DATE 11/19/54
		SHEET 1 OF 4	

CATALOG NUMBER		STUD		CABLE RANGE	A	B	B-90	C	D	F	J
DSC	DSC-90	DIA.	THD.								
DSC-04022-13-3	DSC-04022-90-13-3	0.500	13	#6 SOL. - 2/0 STR.	2.250	5.125	4.625	2.500	2.000	1.250	0.375
DSC-04025-13-3	DSC-04025-90-13-3	0.500	13	#4 SOL. - 250 MCM	2.250	5.250	4.438	2.625	1.875	1.250	0.375
DSC-05025-11	DSC-05025-90-11	0.625	11	#4 SOL. - 250 MCM	2.250	5.125	4.938	2.438	2.250	1.219	0.500
DSC-06022-16-3	DSC-06022-90-16-3	0.750	16	#6 SOL. - 2/0 STR.	2.250	5.125	4.625	2.500	2.000	1.250	0.375
DSC-06025-12-3	DSC-06025-90-12-3	0.750	12	#4 SOL. - 250 MCM	2.250	5.125	4.500	2.500	1.875	1.250	0.375
DSC-06025-12	DSC-06025-90-12	0.750	16	#4 SOL. - 250 MCM	2.250	5.375	--	2.750	2.375	--	0.500
DSC-06025-16-3	DSC-06025-90-16-3	0.750	16	#4 SOL. - 250 MCM	2.250	5.125	4.500	2.500	1.875	1.250	0.375
--	DSC-06050-90-12-3	0.750	12	1/0 SOL. - 500 MCM	2.250	--	4.750	2.750	2.063	1.375	0.375
DSC-06050-16-3	--	0.750	16	1/0 SOL. - 500 MCM	2.250	6.500	--	3.750	2.125	--	0.375
--	DSC-06050-90-16-3	0.750	16	1/0 SOL. - 500 MCM	2.250	--	4.750	2.750	2.125	1.375	0.375
DSC-06050-16	DSC-06050-90-16	0.750	16	1/0 SOL. - 500 MCM	2.250	6.000	4.750	3.750	2.125	1.875	0.500
DSC-094050-0-3	--	0.938	0	1/0 SOL. - 500 MCM	2.250	5.375	4.875	2.750	2.063	1.375	0.375
DSC-10025-14-3	DSC-10025-90-14-3	1.000	14	#4 SOL. - 250 MCM	2.250	5.125	4.438	2.500	1.875	1.250	0.375
DSC-10050-12-3	DSC-10050-90-12-3	1.000	12	1/0 SOL. - 500 MCM	2.250	5.375	4.625	2.750	2.125	1.375	0.375
DSC-10050-14-3	DSC-10050-90-14-3	1.000	14	1/0 SOL. - 500 MCM	2.250	5.375	4.875	2.750	2.063	1.375	0.375
DSC-10080-14-3	DSC-10080-90-14-3	1.000	14	2/0 SOL. - 800 MCM	2.250	5.375	5.125	2.750	2.375	1.375	0.375
DSC-10080-14	DSC-10080-90-14	1.000	14	2/0 SOL. - 800 MCM	2.250	5.375	5.500	2.750	2.875	1.375	0.500
DSC-11025-12-3	DSC-11025-90-12-3	1.125	12	#4 SOL. - 250 MCM	2.250	5.125	4.500	2.500	1.875	1.250	0.375
DSC-11025-12	DSC-11025-90-12	1.125	12	#4 SOL. - 250 MCM	2.250	5.188	4.813	2.500	2.313	1.250	0.500
DSC-11050-12-3	DSC-11050-90-12-3	1.125	12	1/0 SOL. - 500 MCM	2.250	5.438	4.875	2.750	2.125	1.375	0.375
DSC-11050-12	DSC-11050-90-12	1.125	12	1/0 SOL. - 500 MCM	2.250	5.438	5.125	2.750	2.438	1.375	0.500
DSC-11080-12-3	DSC-11080-90-12-3	1.125	12	2/0 SOL. - 800 MCM	2.250	5.375	5.125	2.750	2.375	1.375	0.375
DSC-11080-12	DSC-11080-90-12	1.125	12	2/0 SOL. - 800 MCM	2.250	5.500	5.563	2.750	2.875	1.375	0.500
DSC-11100-12	DSC-11100-90-12	1.125	12	4/0 STR. - 1000 MCM	2.750	6.125	5.563	4.250	2.875	1.750	0.500
DSC-11200-12	--	1.125	12	1500 - 2000 MCM	2.250	6.750	--	4.000	3.375	--	0.500
DSC-12025-12-3	DSC-12025-90-12-3	1.250	12	#4 SOL. - 250 MCM	2.250	5.188	4.625	2.500	1.875	1.250	0.375
DSC-12025-12	DSC-12025-90-12	1.250	12	#4 SOL. - 250 MCM	2.250	5.125	5.000	2.500	2.375	1.250	0.500
DSC-12050-12-3	DSC-12050-90-12-3	1.250	12	1/0 SOL. - 500 MCM	2.250	5.563	4.750	2.750	2.063	1.375	0.375
DSC-12050-12	--	1.250	12	1/0 SOL. - 500 MCM	2.250	5.375	--	2.750	2.500	1.375	0.500
--	DSC-12050-90-12	1.250	12	1/0 SOL. - 500 MCM	2.250	--	5.250	3.750	2.500	1.375	0.500
DSC-12080-12-3	DSC-12080-90-12-3	1.250	12	2/0 SOL. - 800 MCM	2.250	5.125	5.125	2.750	2.375	1.375	0.375
DSC-12080-12	DSC-12080-90-12	1.250	12	2/0 SOL. - 800 MCM	2.250	5.438	5.438	2.750	2.875	1.375	0.500
DSC-12100-12	DSC-12100-90-12	1.250	12	4/0 STR. - 1000 MCM	2.250	6.375	5.750	3.500	2.375	1.750	0.500
DSC-12150-12	DSC-12150-90-12	1.250	12	250 - 1500 MCM	2.250	6.438	6.000	3.750	3.313	1.875	0.500
DSC-12300-12	--	1.250	12	2000 - 3000 MCM	2.250	7.875	--	5.250	3.750	--	0.500

59619	2/23/15	JLB	JLB
EC #	DATE	CHG BY	RESP ENG
DESC OF DWG SEE PAGE 1 -- -- --			
REASON(S) FOR CHANGE: -- DISPOSITION OF MAT'L: --			

ANDERSON®  HUBBELL® POWER SYSTEMS

TITLE: STUD CONNECTOR  
STUD TO CABLE

SIZE	DWG NO.	CAT / PART / ASSY NO.	REV
C	C-2888	SEE TABLE	29
DO NOT SCALE THIS DRAWING		DRN BY RLW	DATE 11/19/54 SHEET 2 OF 4

CONFIDENTIAL: THIS DRAWING AND ITS CONTENTS ARE CONFIDENTIAL AND THE EXCLUSIVE PROPERTY OF HUBBELL POWER SYSTEMS. NO PUBLICATION, DISTRIBUTION OR COPIES MAY BE MADE WITHOUT THE WRITTEN CONSENT OF HUBBELL POWER SYSTEMS. HUBBELL POWER SYSTEMS UNPUBLISHED. ALL RIGHTS RESERVED UNDER THE COPYRIGHT LAWS.

CATALOG NUMBER		STUD		CABLE RANGE	A	B	B-90	C	D	F	J
DSC	DSC-90	DIA.	THD.								
DSC-14025-12-3	DSC-14025-90-12-3	1.500	12	#4 SOL. - 250 MCM	2.250	5.188	4.500	2.500	1.875	1.250	0.375
DSC-14025-12	DSC-14025-90-12	1.500	12	#4 SOL. - 250 MCM	2.250	5.125	4.875	2.500	2.375	1.250	0.500
DSC-14050-12-3	DSC-14050-90-12-3	1.500	12	1/0 SOL. - 500 MCM	2.250	5.375	4.750	2.750	2.125	1.375	0.375
DSC-14050-12	DSC-14050-90-12	1.500	12	1/0 SOL. - 500 MCM	2.250	5.563	5.125	2.750	2.438	1.375	0.500
DSC-14050-14	DSC-14050-90-14	1.500	14	1/0 SOL. - 500 MCM	2.250	5.375	5.125	2.750	2.500	1.375	0.500
DSC-14080-12-3	DSC-14080-90-12-3	1.500	12	2/0 SOL. - 800 MCM	2.250	5.500	5.125	2.750	2.375	1.375	0.375
DSC-14080-12	DSC-14080-90-12	1.500	12	2/0 SOL. - 800 MCM	2.250	5.375	5.500	2.750	2.875	1.375	0.500
DSC-14100-12	DSC-14100-90-12	1.500	12	4/0 STR. - 1000 MCM	2.250	6.250	5.500	3.500	2.875	1.750	0.500
DSCM-14100-12	--	1.500	12	4/0 STR. - 1000 MCM	2.250	6.250	--	3.625	2.875	--	0.500
DSC-14150-12	DSC-14150-90-12	1.500	12	250 - 1500 MCM	2.250	6.563	6.125	3.750	3.313	1.875	0.500
DSC-14200-12	DSC-14200-90-12	1.500	12	500 - 2000 MCM	2.250	6.750	6.125	4.000	3.313	2.000	0.500
DSC-14300-12	--	1.500	12	2000 - 3000 MCM	2.750	7.375	--	4.250	3.750	--	0.500
--	DSC-14300-90-12	1.500	12	2000 - 3000 MCM	2.250	--	6.250	5.250	3.688	2.625	0.500
DSC-16050-12	DSC-16050-90-12	1.750	12	1/0 SOL. - 500 MCM	2.250	5.438	5.000	2.750	2.438	1.375	0.500
DSC-16080-12	DSC-16080-90-12	1.750	12	2/0 SOL. - 800 MCM	2.250	5.500	5.625	2.750	2.875	1.375	0.500
DSC-16100-12	DSC-16100-90-12	1.750	12	4/0 STR. - 1000 MCM	2.250	6.250	5.750	3.500	3.000	1.750	0.500
DSC-16150-12	DSC-16150-90-12	1.750	12	250 - 1500 MCM	2.250	6.500	6.000	3.750	3.250	1.875	0.500
DSC-16200-12	DSC-16200-90-12	1.750	12	500 - 2000 MCM	2.250	6.750	6.125	4.000	3.375	2.000	0.500
DSC-20025-12	DSC-20025-90-12	2.000	12	#4 SOL. - 250 MCM	2.250	5.250	5.000	2.438	2.250	1.250	0.500
DSC-20050-12	DSC-20050-90-12	2.000	12	1/0 SOL. - 500 MCM	2.250	5.500	5.250	2.750	2.438	1.750	0.500
DSC-20080-12	DSC-20080-90-12	2.000	12	2/0 SOL. - 800 MCM	2.250	5.500	5.750	2.750	2.875	1.375	0.500
DSC-20100-12	DSC-20100-90-12	2.000	12	4/0 STR. - 1000 MCM	2.250	6.125	5.750	3.500	2.875	1.750	0.500
DSC-20150-12	DSC-20150-90-12	2.000	12	250 - 1500 MCM	2.250	6.688	6.000	3.750	3.313	1.875	0.500
DSC-20200-12	DSC-20200-90-12	2.000	12	500 - 2000 MCM	2.250	6.875	6.125	4.000	3.313	2.000	0.500
DSC-20300-12	DSC-20300-90-12	2.000	12	2000 - 3000 MCM	2.250	8.250	6.469	5.250	3.750	2.625	0.500
--	DSC-22050-90-12	2.250	12	1/0 SOL. - 500 MCM	2.000	--	5.313	2.750	2.438	1.375	0.500
DSC-22080-12	DSC-22080-90-12	2.250	12	2/0 SOL. - 800 MCM	2.250	5.500	5.625	2.750	2.875	1.375	0.500
DSC-22100-12	DSC-22100-90-12	2.250	12	4/0 STR. - 1000 MCM	2.250	6.500	5.750	3.500	2.875	1.750	0.500
DSC-22150-12	DSC-22150-90-12	2.250	12	250 - 1500 MCM	2.250	6.500	6.000	3.750	3.250	1.875	0.500
DSC-22200-12	DSC-22200-90-12	2.250	12	500 - 2000 MCM	2.250	6.750	6.125	4.000	3.750	2.000	0.500
DSC-24050-12	DSC-24050-90-12	2.500	12	1/0 SOL. - 500 MCM	2.750	6.094	5.563	2.750	2.438	1.375	0.500
DSC-24080-12	DSC-24080-90-12	2.500	12	2/0 SOL. - 800 MCM	2.750	6.125	6.375	2.750	2.875	1.375	0.500
DSC-24100-12	DSC-24100-90-12	2.500	12	4/0 STR. - 1000 MCM	2.750	6.875	6.250	3.500	2.875	1.750	0.500
DSC-24150-12	DSC-24150-90-12	2.500	12	250 - 1500 MCM	2.750	7.000	6.500	3.750	3.250	1.875	0.500
DSC-24200-12	DSC-24200-90-12	2.500	12	500 - 2000 MCM	2.750	7.250	6.625	4.000	3.375	2.000	0.500

59619	2/23/15	JLB	JLB
EC #	DATE	CHG BY	RESP ENG
DESC OF DWG SEE PAGE 1 -- -- --			
REASON(S) FOR CHANGE: -- DISPOSITION OF MAT'L: --			

ANDERSON®  HUBBELL® POWER SYSTEMS

TITLE: STUD CONNECTOR  
STUD TO CABLE

CONFIDENTIAL: THIS DRAWING AND ITS CONTENTS ARE CONFIDENTIAL AND THE EXCLUSIVE PROPERTY OF HUBBELL POWER SYSTEMS. NO PUBLICATION, DISTRIBUTION OR COPIES MAY BE MADE WITHOUT THE WRITTEN CONSENT OF HUBBELL POWER SYSTEMS. HUBBELL POWER SYSTEMS UNPUBLISHED. ALL RIGHTS RESERVED UNDER THE COPYRIGHT LAWS.

SIZE	DWG NO.	CAT / PART / ASSY NO.	REV
C	C-2888	SEE TABLE	29
DO NOT SCALE THIS DRAWING	DRN BY RLW	DATE 11/19/54	SHEET 3 OF 4

CATALOG NUMBER		STUD		CABLE RANGE	A	B	B-90	C	D	F	J
DSC	DSC-90	DIA.	THD.								
DSC-30025-12	DSC-30025-90-12	3.000	12	#4 SOL. - 250 MCM	3.250	--	6.000	2.438	2.250	1.219	0.500
DSC-30050-12-3	--	3.000	12	1/0 SOL. - 500 MCM	2.750	7.063	--	3.750	2.125	--	0.375
DSC-30100-12	DSC-30100-90-12	3.000	12	4/0 STR. - 1000 MCM	3.250	7.375	6.750	3.500	2.875	1.750	0.500
DSC-30080-12	DSC-30080-90-12	3.000	12	500 - 800 MCM	3.250	6.625	6.750	2.750	2.875	1.375	0.500
DSC-30150-12	DSC-30150-90-12	3.000	12	250 - 1500 MCM	3.250	7.625	6.500	3.750	3.313	1.875	0.500
DSC-30200-12	DSC-30200-90-12	3.000	12	500 - 2000 MCM	3.250	7.875	7.188	4.000	3.375	2.000	0.500
DSC-32100-12	DSC-32100-90-12	3.250	12	4/0 STR. - 1000 MCM	3.250	7.375	6.125	3.500	2.875	1.750	0.500
DSC-32150-12	DSC-32150-90-12	3.250	12	250 - 1500 MCM	2.750	7.000	6.500	3.750	3.250	1.875	0.500
DSC-32200-12	DSC-32200-90-12	3.250	12	1500 - 2000 MCM	2.750	7.250	6.625	4.000	3.375	2.000	0.500
--	DSC-40050-90-10	4	10	1/0 SOL. - 500 MCM	4.000	--	7.063	2.750	2.438	1.375	0.500
DSC-40150-12	--	4	12	250 - 1500 MCM	4.000	8.375	--	3.750	3.375	--	0.500

59619	2/23/15	JLB	JLB
EC #	DATE	CHG BY	RESP ENG
DESC OF DWG SEE PAGE 1			
REASON(S) FOR CHANGE: --			
DISPOSITION OF MAT'L: --			

ANDERSON®



HUBBELL® POWER SYSTEMS

CONFIDENTIAL: THIS DRAWING AND ITS CONTENTS ARE CONFIDENTIAL AND THE EXCLUSIVE PROPERTY OF HUBBELL POWER SYSTEMS. NO PUBLICATION, DISTRIBUTION OR COPIES MAY BE MADE WITHOUT THE WRITTEN CONSENT OF HUBBELL POWER SYSTEMS. HUBBELL POWER SYSTEMS UNPUBLISHED ALL RIGHTS RESERVED UNDER THE COPYRIGHT LAWS.

TITLE STUD CONNECTOR STUD TO CABLE			
SIZE C	DWG NO. C-2888	CAT / PART / ASSY NO. SEE TABLE	REV 29
DO NOT SCALE THIS DRAWING	DRN BY RLW	DATE 11/19/54	SHEET 4 OF 4